

### Benefits of the Testing Facility

- Reliable recognition of dangerous objects/vehicles before entering a tunnel
- Indication of secondary hazards such as queues or any other dangerous situation
- Early detection of warnings and hazard situations due to faults which are shown as a hotspot - such wheel bearings, brakes, tyres, overloads etc
- Acquisition of relevant data on fire hazards (cars, heavy goods vehicles and coaches) for prevention planning.
- 100% object data recording for subsequent evaluation and scientific examination

### Testing Facility Installation

- The TIC system forms ECTN's basis. The Traffic Information Collector (TIC) is used for 3 dimensional object recognition of vehicles at speeds of up to 130 km/h and records the height, width, depth and speed of the vehicle. The system classifies the vehicle using these dimensions. The technology used in the TIC system is based on SICK laser scanners.
- Together with the TIC data, thermal imaging data from the vehicles is also recorded.
- The measured vehicle data is combined and integrated to show the vehicle's heat distribution. Hotspots are detected, located and identified as dangerous or otherwise. This is the fundamental difference when compared to other existing systems: the exact locating of the measured temperatures to the precisely measured 3 D objects.
- If the defined, potentially dangerous limit values are exceeded the alarm signal is immediately raised and communicated to the control centre.
- The control centre then organizes the removal of the vehicles and prevents entry into the tunnel.

### ECTN's Capabilities

- Processing of high data rates and complex data streams
- Object analysis
- Broad spectrum of competence in the field of 3D object measuring in the area  $\mu\text{m}$  to cm in the industrial environment as well as open air test sites
- Recording and visualisation of 3D objects and textures particularly with thermo data and object geometry. Geometrically precise triggering of objects for image synchronisation
- Multi-purpose software applications including authenticity controls

### ECTN's Reference Assets

- BLS/SBB profile locating and excess speed detection at speeds up to 160 km/h (comparable projects are not known to be offered by other suppliers)
- Gotthard „Tropfenzähler“ (“Drop Counter” or “Flow Regulator”) sensor system and data interface
- Gubrist height control with traffic classification
- HGV Profile measuring with Federal Roads Office Certification
- Dangerous goods recognition projects with InNet
- Dangerous goods recognition with „Autobahndirektion Südbayern“ (South Bavarian Motorway Authority)
- Heavy goods traffic control centres with data management
- Realisation of various industrial projects with own framework tool - from feasibility studies on Fast Prototyping to end product - with system high availability
- Field tests at Ohringen, Göschenen Tropfenzähler (“Drop Counter”)
- Mobile measuring station with hardware sensor systems and computer

*Images of our 3D object data acquisition (roads)*

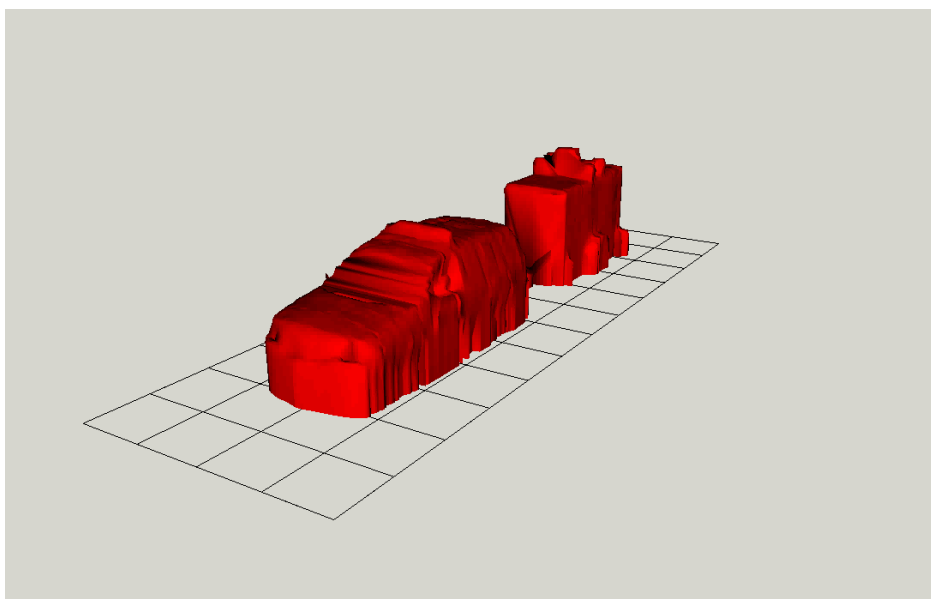
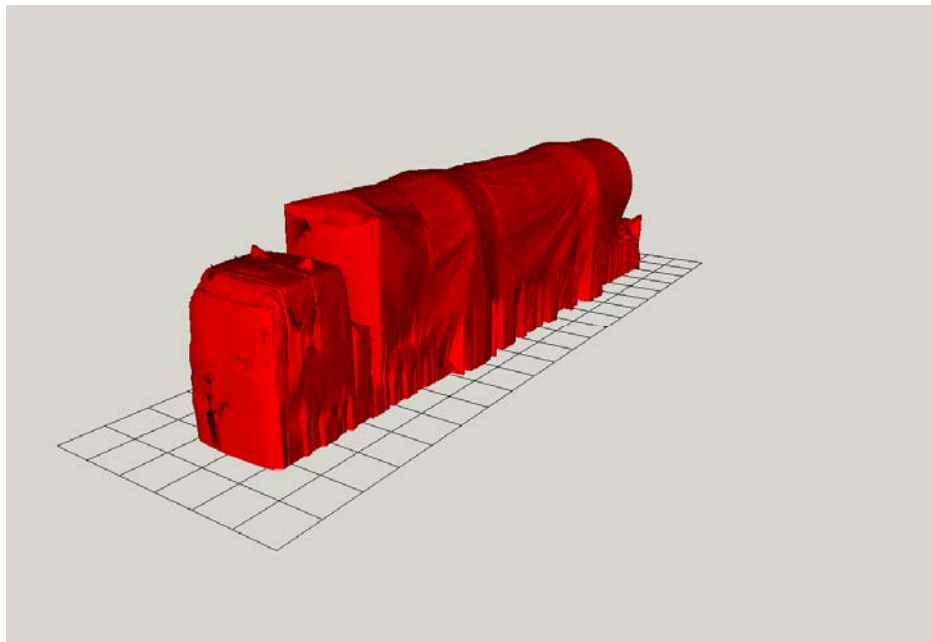
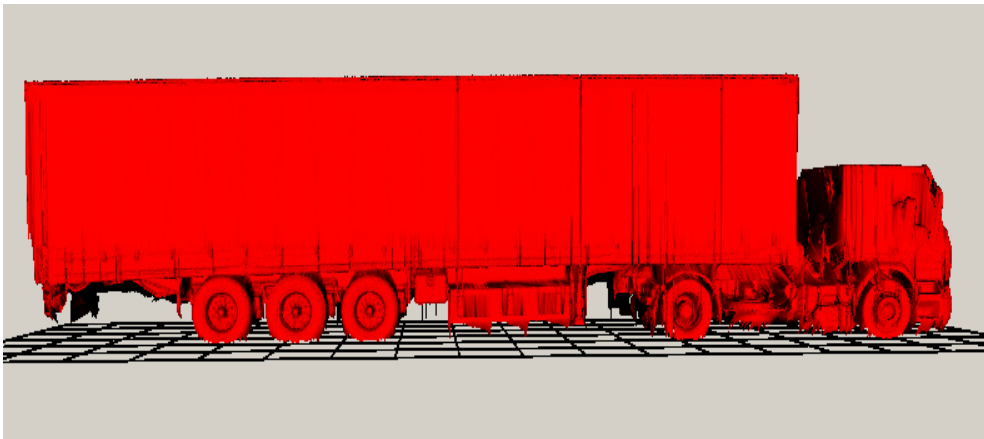

*Images of our 3D object data acquisition (rail)*

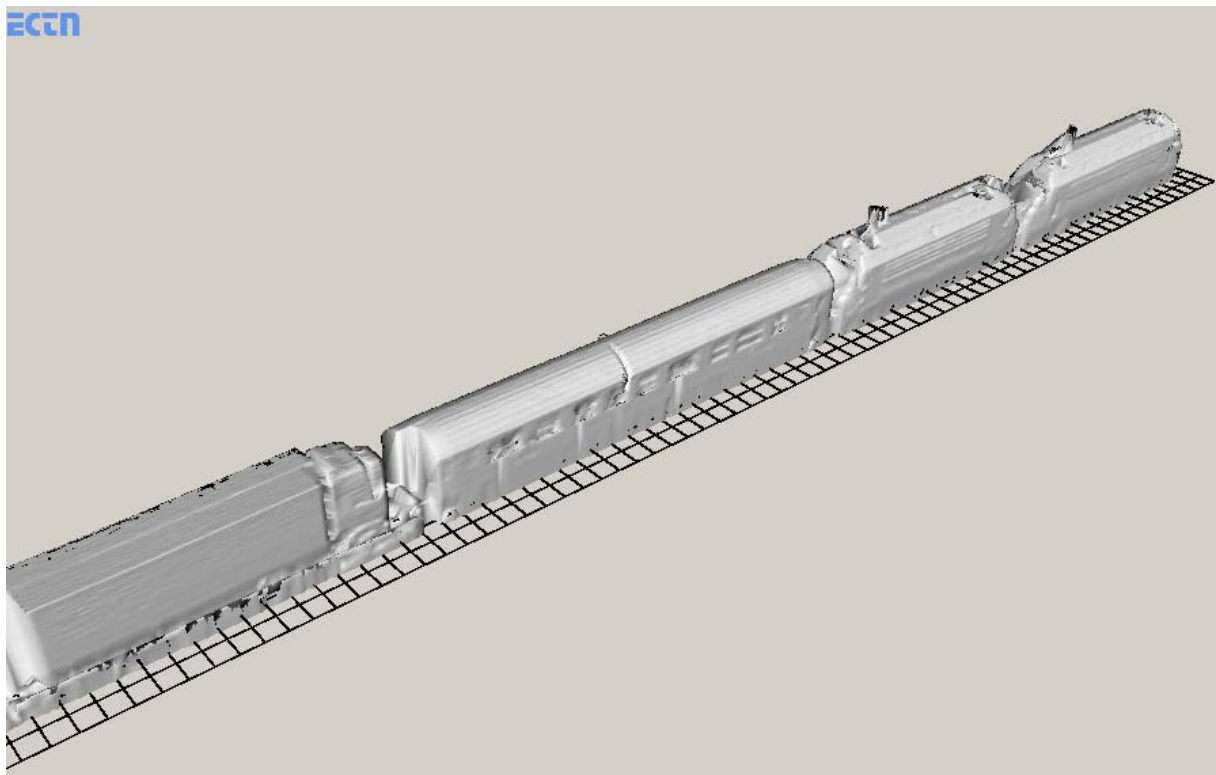
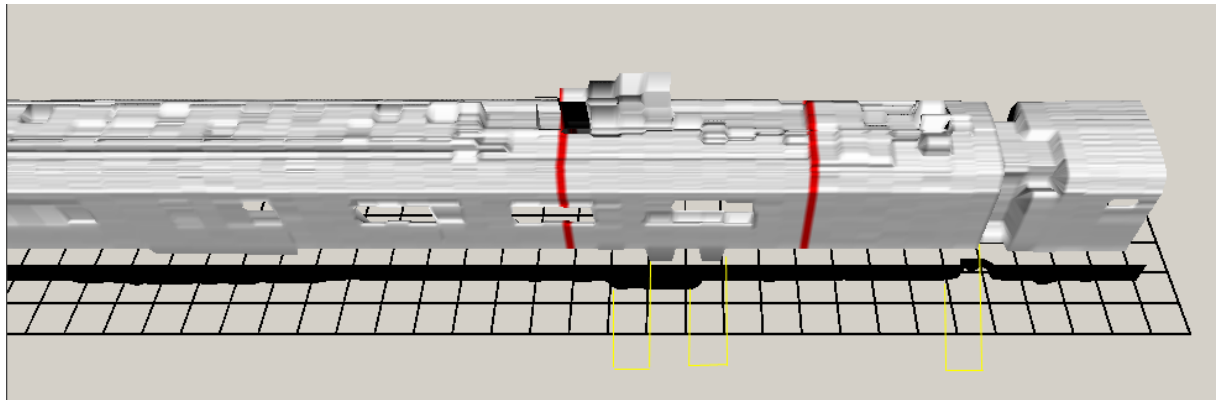

Goods train 90km/h (resolution details)

Combination of 3D and thermo data

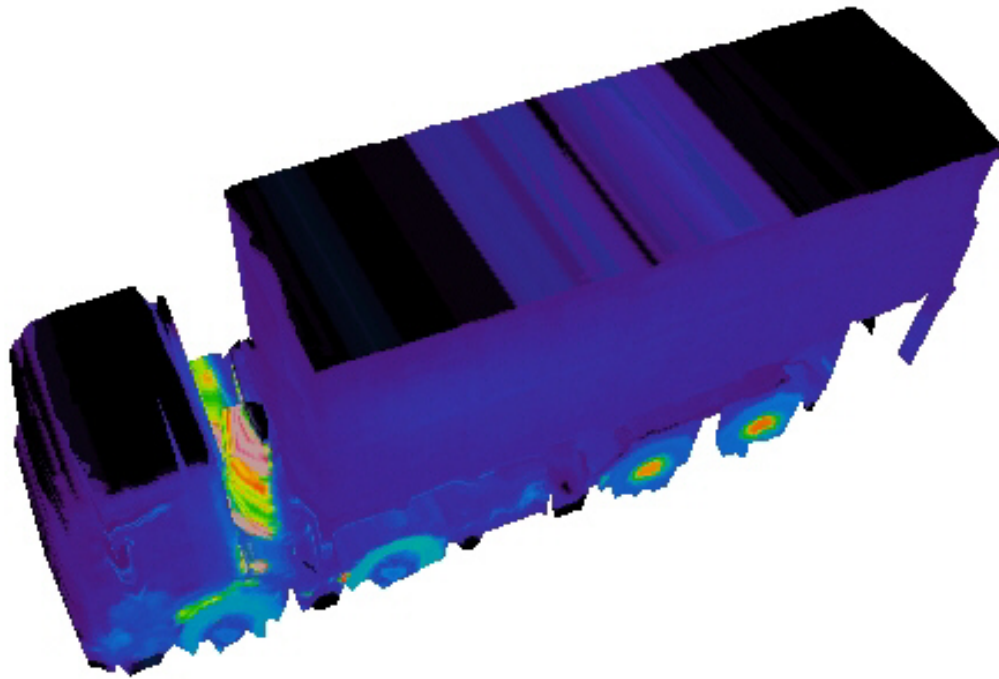

Diverted vehicle: view of exhaust system and turbo charger. Both rear axels are visibly warmer (braking energy)

Reference Assets



Field measuring in Göschenen 2005



TIC System in Airolo on the south side of the Gotthard tunnel